



No. 191 / Store/LTI/2013

Bilaspur, Date: 15/5/13

Limited Tender Enquiry

To,

Subject:- Limited tender enquiry .

Please quote your competitive rates for supply of the Chair, Dining Table & Bench as mentioned below in the prescribed proforma Annexure -1 so as to reach to the office of Dy. Registrar (Stores), Guru Ghasidas Vishwavidyalaya, Koni, Bilaspur – 495009 (C.G.) on or before 30.05.13 through Speed post/Registered post/Courier only.

No.	Description	Qty.
1	Chairs	375
2	Dining Table	46
3	Bench	92

Note : Details and diagram of Chair, Dining table & Bench is enclosed herewith as Annexure –II

General terms & conditions of the supply

1. The sealed quotation should be superscribed with "Quotation for supply of Chair, Dining Table & Bench."
2. **Quantity:** The quantity mentioned above is indicative and may increase or decrease at the time of placing Purchase Order.
3. Technical brochure/leaflet etc. of the quoted items may be submitted along with the quotation.
4. **Discount, if any:** Special concession/discount applicable for Educational Institutions, if any, must be clearly mentioned at the time of submission of quotation.
5. The rate should be quoted on F.O.R. University Campus, Koni, Bilaspur basis. No packing/forwarding charges will be paid extra.
6. The article must be delivered without any extra cost at the University.
7. **Validity of rate:** The quoted rate should be valid for a minimum period of 90 days.
8. **Delivery period:** The article to be delivered within 30 days from the issue of Purchase Order.
9. **Liquidated Damages:** Any delay in supplying the article from the stipulated date of delivery, will attract LD. Liquidated Damage will be applicable at the rate of 0.5% per week and limited to 10% maximum. The authority reserves the right to cancel the purchase order when LD accumulates to 10%.
10. **Payment:** 100% payment will be made after supply of ordered quantity of article at our end in good condition. No advance or partial payment request will be entertained.
11. **Tax** will be paid extra, if applicable provided it is made clear in the quotation.
12. Unsealed quotations will be rejected and quotations must reach on or before the due date through Speed post/Registered post / courier only.
13. University reserves the right to accept or reject any quotation without assigning any reason thereof.

Dy. Registrar (Stores)

Rates of Chair, Dining Table & Bench Ref.:/ Store/ LTI/2013 dated -----

S.No	Description/Specifications	Rate (in Rs.)	Tax or Any Other Charge	Total (Rs.)
1	<p align="center">Chair</p> <p>1. Seat 46cmx46cm, Laminated Plywood, Laminated on both the sides thickness 25mm 2. Back Rest 47cmx15cm x20mm thick both side laminated ply (Drawing of chair enclosed)</p>			
2	<p align="center">Dining Table</p> <p>Top made of plywood 25mmthick , Covered with Stainless Steel (Grade 20 gauge 24), (Drawing of Dining Table enclosed) Size: 8'x3'6 " x2'6"</p>			
3	<p align="center">Bench</p> <p>Top made of plywood 25mmthick , Covered with Stainless Steel (Grade 20 gauge 24), (Drawing of Dining Bench enclosed) Size: 6'x1'6 " x1'6"</p>			
4	<p align="center">Dining Table</p> <p>Top made of plywood 25mmthick , Covered with Stainless Steel (Grade 20 gauge 24), (Drawing of Dining Table enclosed) Size: 6'x3'6 " x2'6"</p>			
5	<p align="center">Bench</p> <p>Top made of plywood 25mmthick , Covered with Stainless Steel (Grade 20 gauge 24), (Drawing of Dining Bench enclosed) Size: 6'x1'4 " x1'6"</p>			

----- declare that the rates will be valid for 90 days.

Date :

Signature and Seal of Tenderer

Mobile No. -----

STUDENT CHAIR

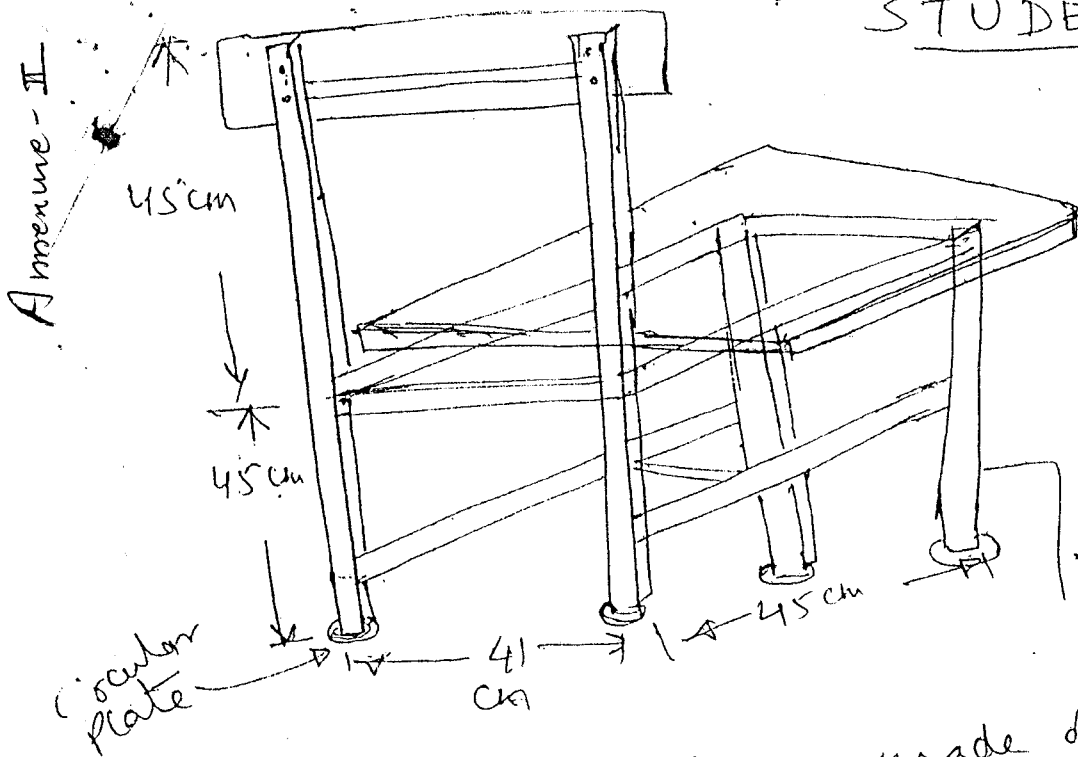

- Seat 46 cm x 46 cm, made of Laminated Plywood, Laminated on both the sides thickness 25 mm.
- Back Rest 47 cm x 15 cm x 20 mm thick Both sides Laminated ply.

3/2/21

Skinned



Amennue

DRAWING OF DINING TABLE FOR MESS

(stiffener)
M.S. plate
1" wide

Length = 8'

width = 36"

Height = 26"

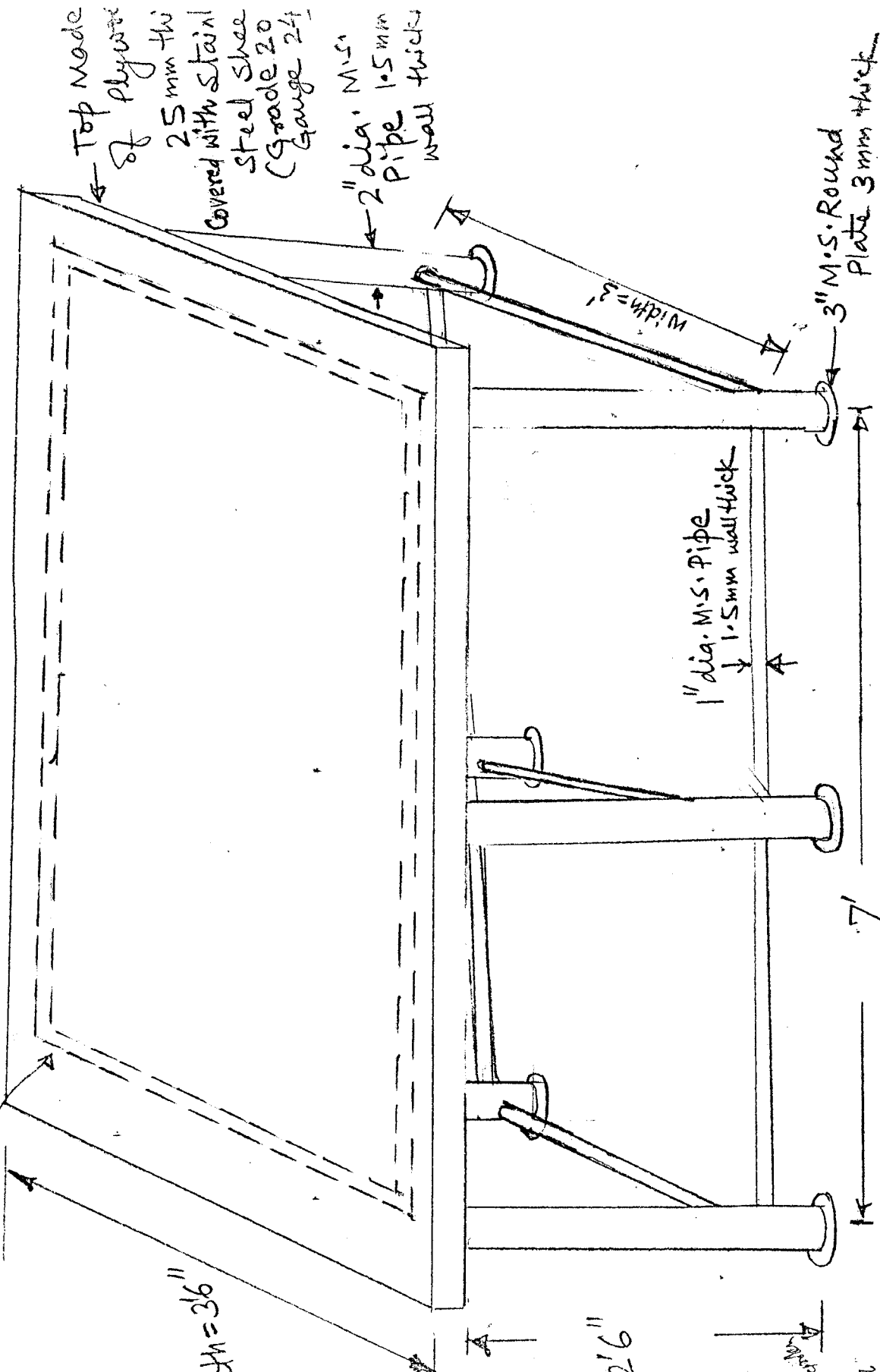

21/11/13
Stainless Steel
24 Gauge
25 mm thick
21/11/13

21/11/13

DRAWING OF DINING BENCH FOR MESS

Top made of Plywood 25mm thick
 covered with stainless steel sheet (Grade 202
 Gauge 24)

Length = 6'

Width 1'6"

Height 1'6"

13/16" dia. M.S. pipe
 1/2" dia. M.S. pipe
 1" dia. M.S. pipe
 3" M.S. Round Plate
 3mm #

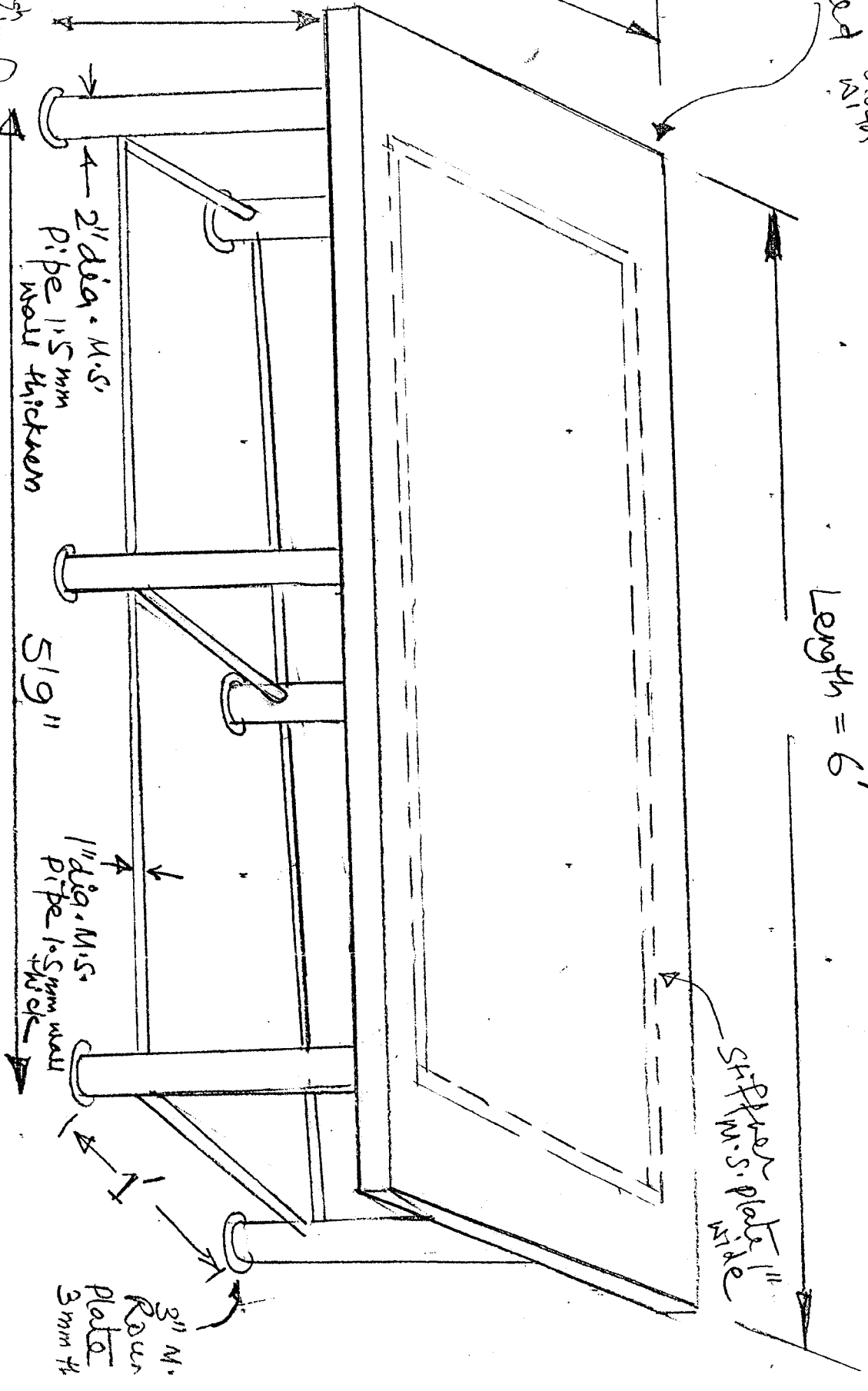

3" M.S. Round Plate
 3mm #

2" dia. M.S. pipe
 1.5 mm wall thickness

5/8"

1" dia. M.S. pipe
 1.05 mm wall thickness